

CHUNK 500MM

ez ASSEMBLY INSTRUCTIONS

Coffee Tables



scan me

PARTS:

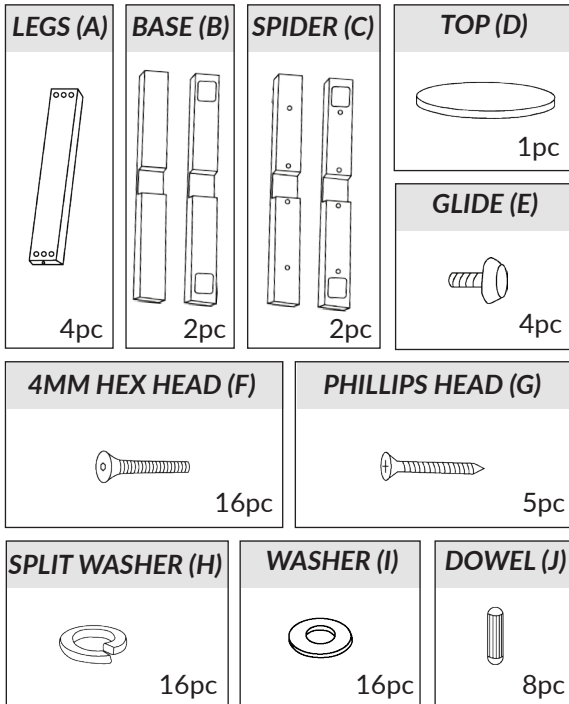

TOOLS (NOT INCLUDED):

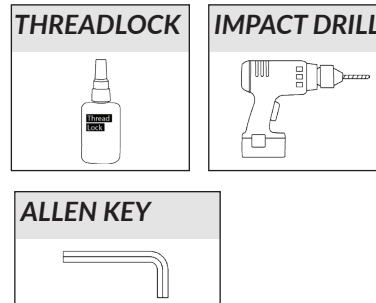

We strongly recommend applying thread lock to the full length of all screws and using an impact drill with attachment if possible. Scan the QR code with a phone or tablet to access the assembly video.

WARNING:

Always take care with a impact drill, especially when screwing into the top.

INSTRUCTIONS:

